



Incorporating



Grilles & Diffusers

Series ECG/ECG45 Egg crate grilles

- Industry standard extract grille
- Standard 0° core or optional 45°
- High performance with minimum pressure drops and noise generation
- Hinged and removable cores
- Popular sizes held in stock for immediate despatch

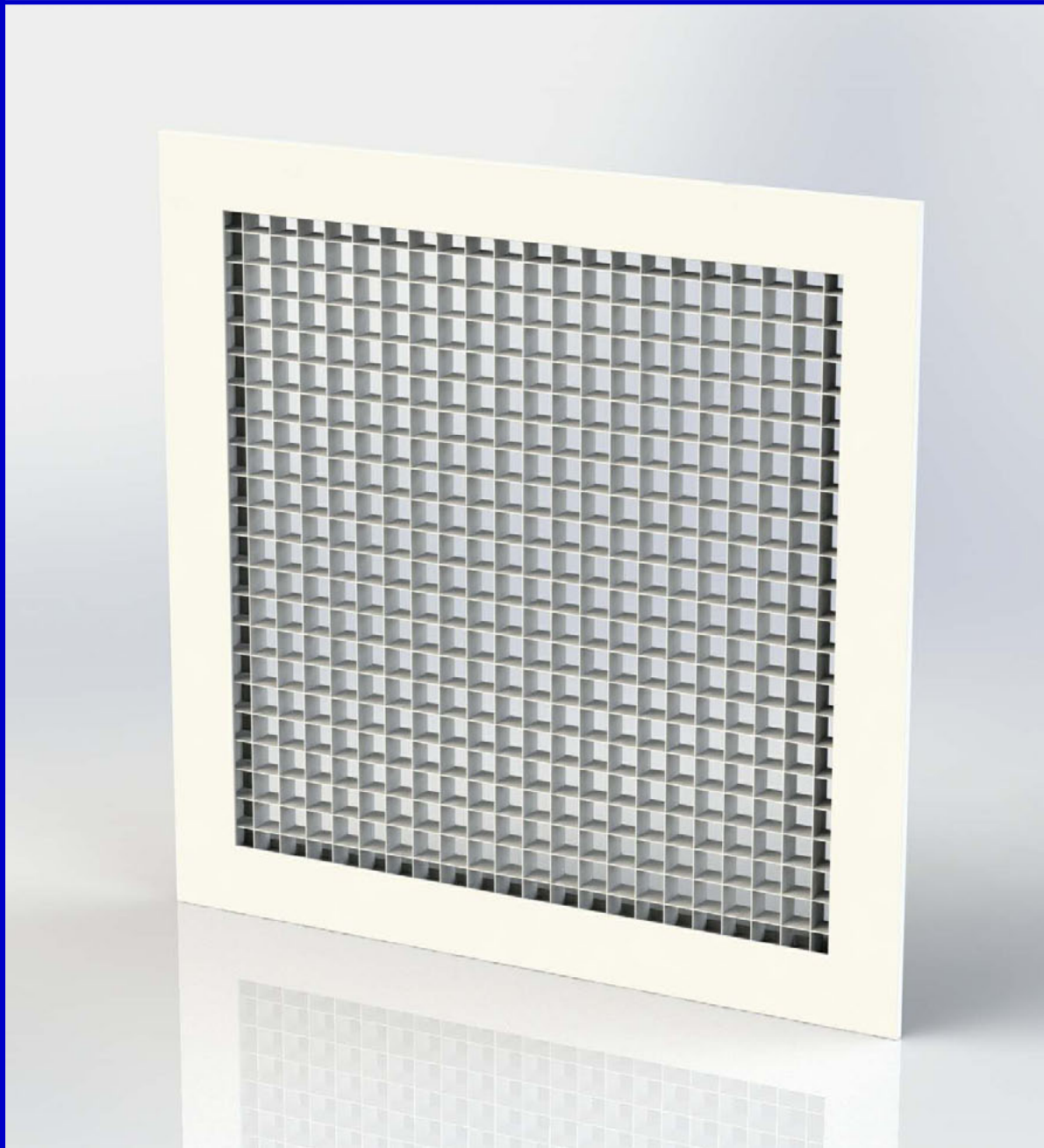

Series ECG/ECG45

Series ECG egg crate grilles are the industry standard extract grille.

Comprising a core with over 90% free area with vanes parallel to airflow, egg crate grilles are capable of handling huge air volumes with minimal noise generation or pressure drop. Ideal for areas requiring high changeover rates like restaurant kitchens, painting booths etc.

A 45° core is also available, with a similar high free area, but introducing non vision properties from certain angles, or giving an angled throw if used for supply.

We hold large quantities of popular sizes of ECG in stock, giving us the capability to supply even the largest orders on a next day basis.

For non standard sizes, units are manufactured to order.

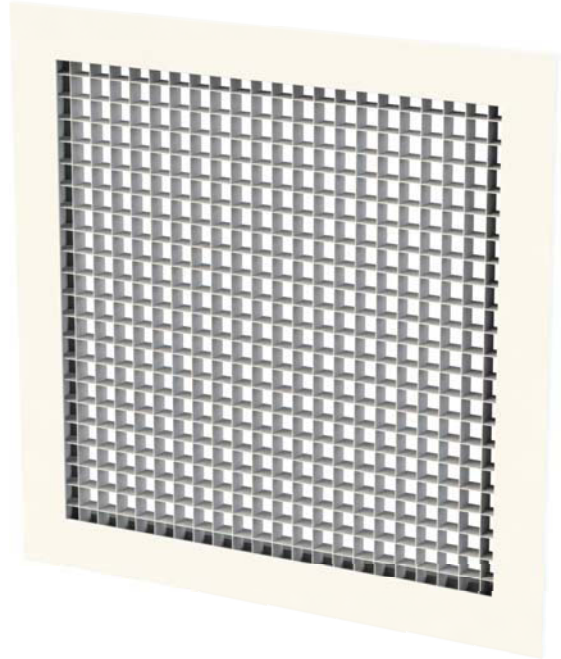

Design features

Material	Aluminium frame and core
Frame	Standard: 30FE - 30mm flat Optional: 37BE - 37mm bevelled 50FE - 50mm flat SMS - Surface mounted small
Sizes	Minimum: 100mm x 50mm Maximum: 2900mm x 2900mm Maximum core size is 1300mm x 1300mm, above this mullions will be used
Fixings	Standard: None Optional: See page 6
Finish	Standard: Satin anodised (AA5) frame (not with 50FE), mill aluminium core Optional: See page 8 Stock units are powder coated RAL9010
Mass/m² face area	4 kg 12 kg including opposed blade damper
Free area	Approx 90%

Quality assurance

HVC Supplies (Stourbridge) Ltd is an ISO 9001 certified company.



Assessed to ISO 9001
Cert/Ref No. 1186

Technical drawings

Standard

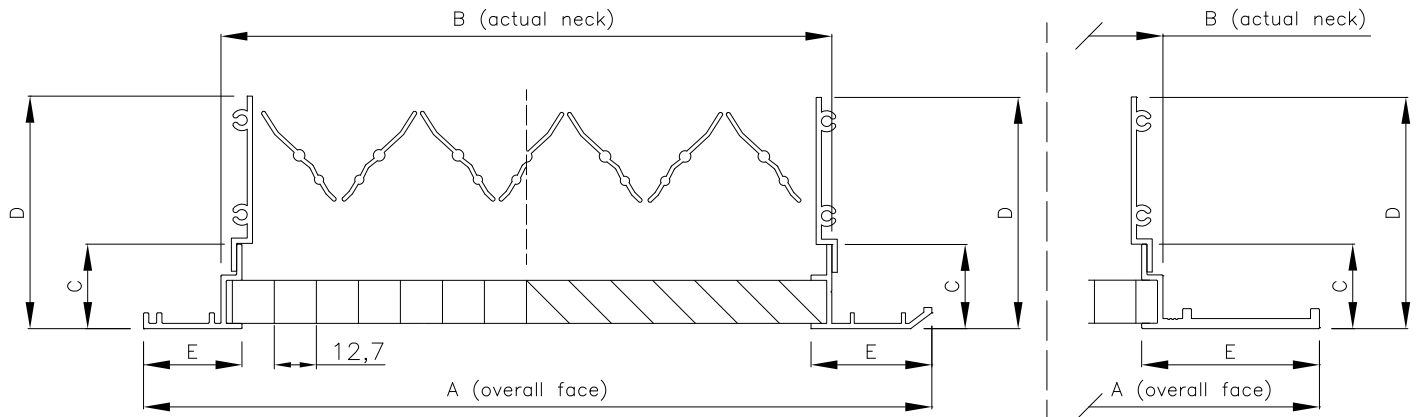

30FE: 30mm flat (standard)	
A	Nominal + 40mm
B	Nominal - 7mm
C	25mm
D	70mm
E	30mm

37BE: 37mm bevelled (optional)	
A	Nominal + 45mm
B	Nominal - 15mm
C	25mm
D	70mm
E	37mm

50FE: 50mm flat (optional)	
A	Nominal + 80mm
B	Nominal - 15mm
C	25mm
D	70mm
E	54mm

Please note: If a tile replacer size is required, for example 595mm x 595mm or 1195mm x 595mm, a 30FE 30mm flat frame should be specified.

Surface mounted

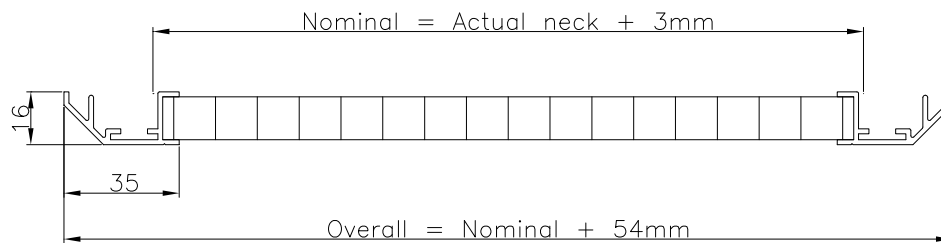

Stocked sizes

The following sizes of Series ECG egg crate grilles are held in stock, with and without fitted opposed blade dampers, in RAL9010 finish and with prepunched fixing holes, available for immediate despatch.

150mm²
200mm²
250mm²
300mm²
350mm²
400mm²

450mm²
500mm²
565mm² (595mm² overall face size tile replacer, no fixing holes)

All sizes are nominal unless stated.

Product codes: ECG - 30FE - (FH) - RAL9010
(grille only)

ECG - 30FE - (FH) - D - RAL9010
(grille complete with fitted opposed blade damper)

Removable core

Fitted with spring loaded quarter turn fasteners, the outer frame has angle brackets fixed to the inside of the neck.

The inner removable frame holds the chrome plated, slotted head studs, for removal with a flathead screwdriver.

Other stud types are available for use with allen keys, or with a larger head for removal by hand.

Please note: Images show grille with the optional 32BS frame.



Ordering code for type shown here: RC-QT

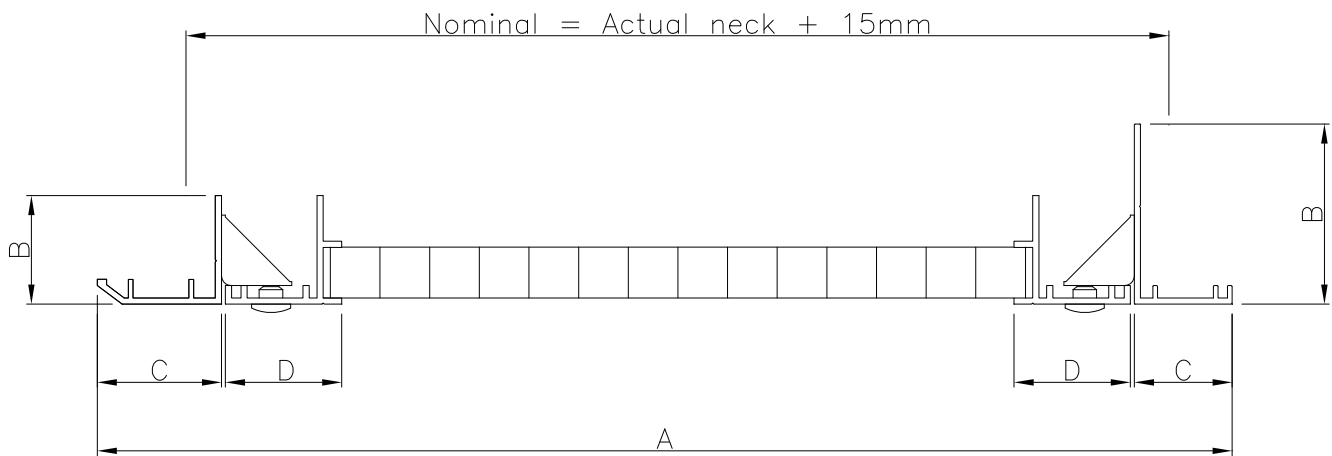

32BS: 32mm bevelled (optional)	
A	Nominal + 45mm
B	28mm
C	32mm
D	30mm

25F: 25mm flat (standard)	
A	Nominal + 30mm
B	46mm
C	25mm
D	30mm

Hinged core

Enabling the core to hinge outwards may be preferable to it being fully removable.

The full length piano hinge at one side is discreet, and gives minimal loss of core area.

The inner core is held in place by one or more M6 panhead bolts mating with nutserts mounted to a concealed rear frame extension.

Chrome plated cam fasteners are optional instead of bolts.

Please note: Images show grille with the optional 32BZ frame.



Ordering code for type shown here: HC-BLT

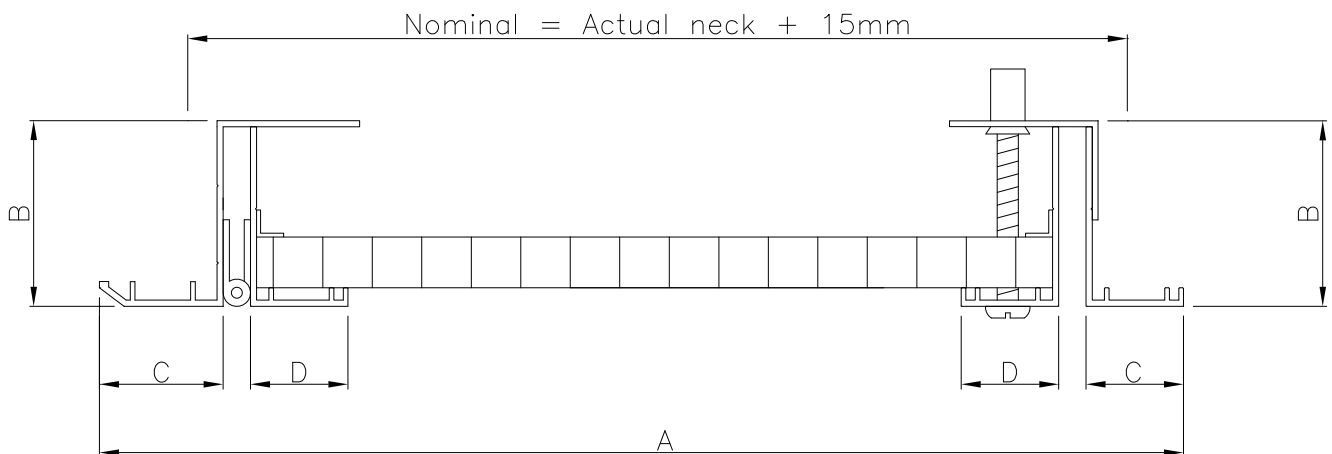

32BZ: 32mm bevelled Z (optional)	
A	Nominal + 45mm
B	48mm
C	32mm
D	25mm

25F: 25mm flat (standard)	
A	Nominal + 30mm
B	48mm
C	25mm
D	25mm

Fixings

Countersunk fixing holes: Code suffix FH

For extremely simple fitting, countersunk fixing holes can be punched into the outer frame.

Self tapping screws in the same finish as the grille are provided as standard.

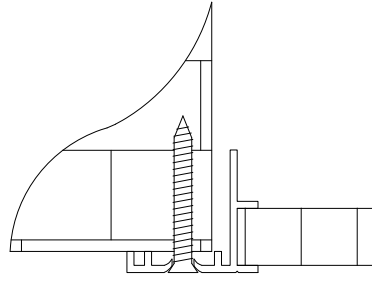

Push-in clip method: Code suffix PC

These sprung clips are compressed when the grille is pushed into place. The outward force provided then holds the grille securely in place.

This fixing method is not suitable for use in ceilings.

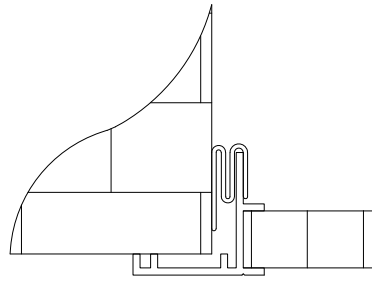

Concealed fixings: Code suffix CF

Recently redesigned, concealed fixings comprise two small lengths of aluminium angle, one with a punched slot, the other with a factory fitted nutsert.

The punched bracket should be fitted to the grille neck, and the bracket with nutsert fixed to the inside of the plenum, duct or builderswork opening.

Factory supplied bolts can then be used to pull the grille securely into place.

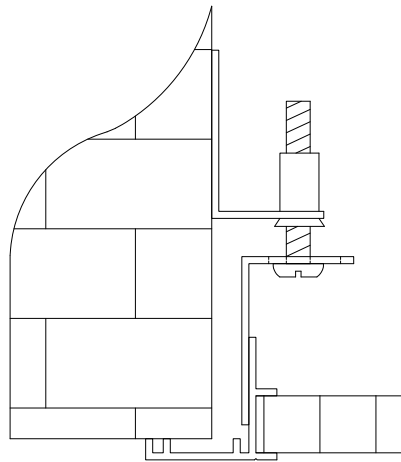

Selection data

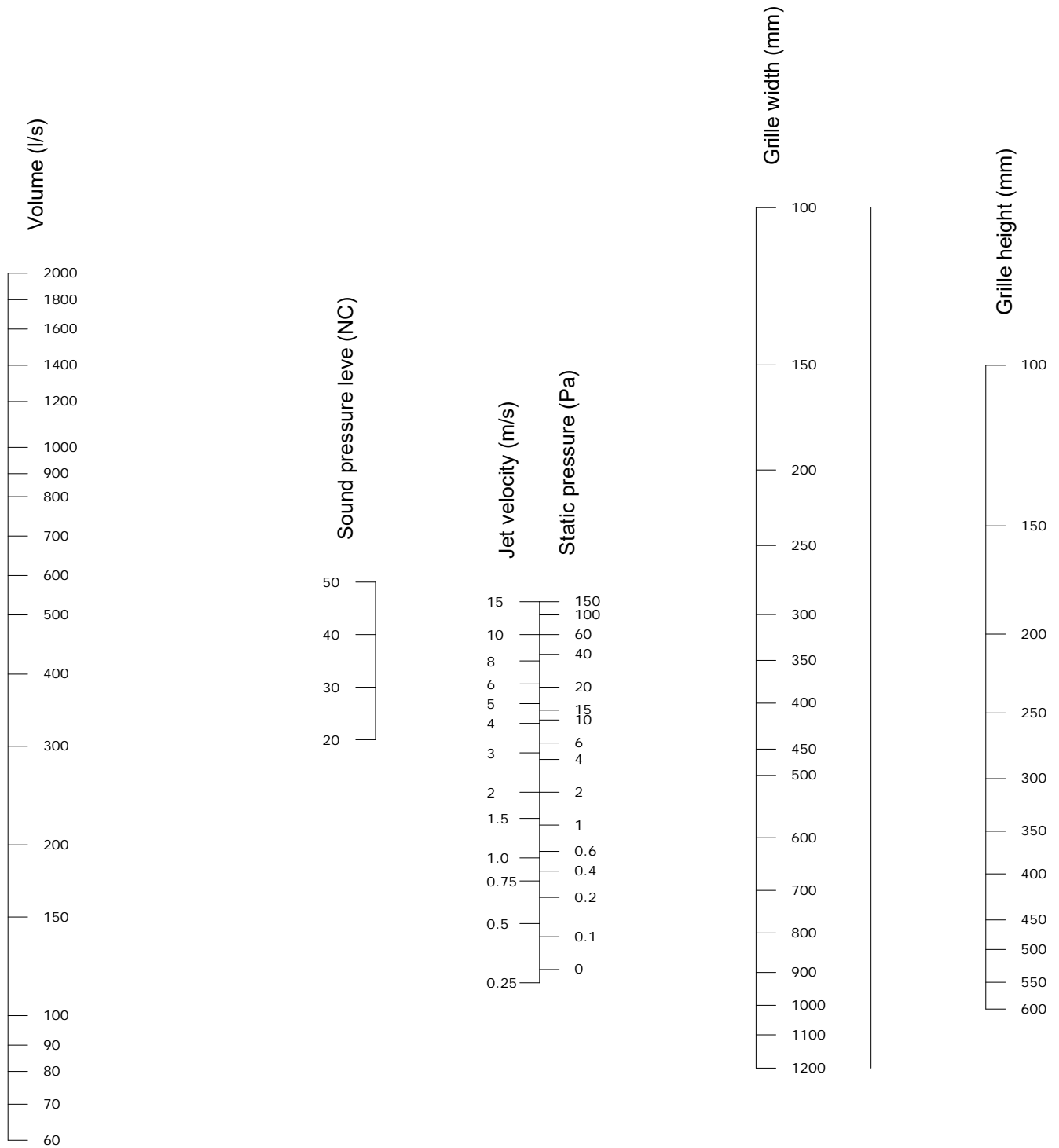

Finishes

Mill aluminium

Satin anodised aluminium (frame only, core mill, not with 50FE)

Polyester powder coating to any RAL or BS colour



Ordering codes

Example

1 - 400 x 400 - ECG - D - 30FE - FH - RAL9010

Codes

1)	Quantity		
2)	Size (mm)	(Width x height)	
3)	Series	ECG ECG45	Egg crate grille Egg crate grille 45° core (specify blow direction if not a square size)
4)	Damper	D	Opposed blade damper fitted
5)	Frame	30FE 37BE 50FE SMS	30mm flat (standard, recommended for tile replacer sizes) 37mm bevelled 50mm flat Surface mounted
6)	Fixings	FH CF PC	Countersunk fixing holes (screws supplied in same finish) Concealed fixings (not suitable for grilles with 'SMS' frame) Push-in clips (not for use in ceilings, not suitable for grilles with 'SMS' frame)
7)	Core type	RC-QT HC-BLT HC-CAM	Removable core - Quarter turn type (standard method) Hinged core - Bolt type (standard method) Hinged core - Cam fastener (optional)
8)	Finish	SAA Mill RAL... BS...	Satin anodised frame, mill finish core (standard, not with 50FE) Mill aluminium (standard with 50FE) Polyester powder coated to RAL... Polyester powder coated to BS...

Important: Size will be taken to be nominal (hole internal) unless stated otherwise.

Leave code section blank if no option is required.

Specification of a hinged or removable core will mean 30FE, 37BE and 50FE frames cannot be used. In this instance a standard 25mm flat frame, optional 32mm bevelled or 50mm flat frame will be substituted.

HVC & NCA products

HVC offer the significant advantage of manufacturing both in duct and duct terminal equipment, making us a one stop shop for all your HVAC needs.

The products shown below are a selection, not an exhaustive list. Go to www.h-v-c.com for details on all HVC and NCA products.

HVC: Grilles, Diffusers, Louvres and Volume Control Dampers

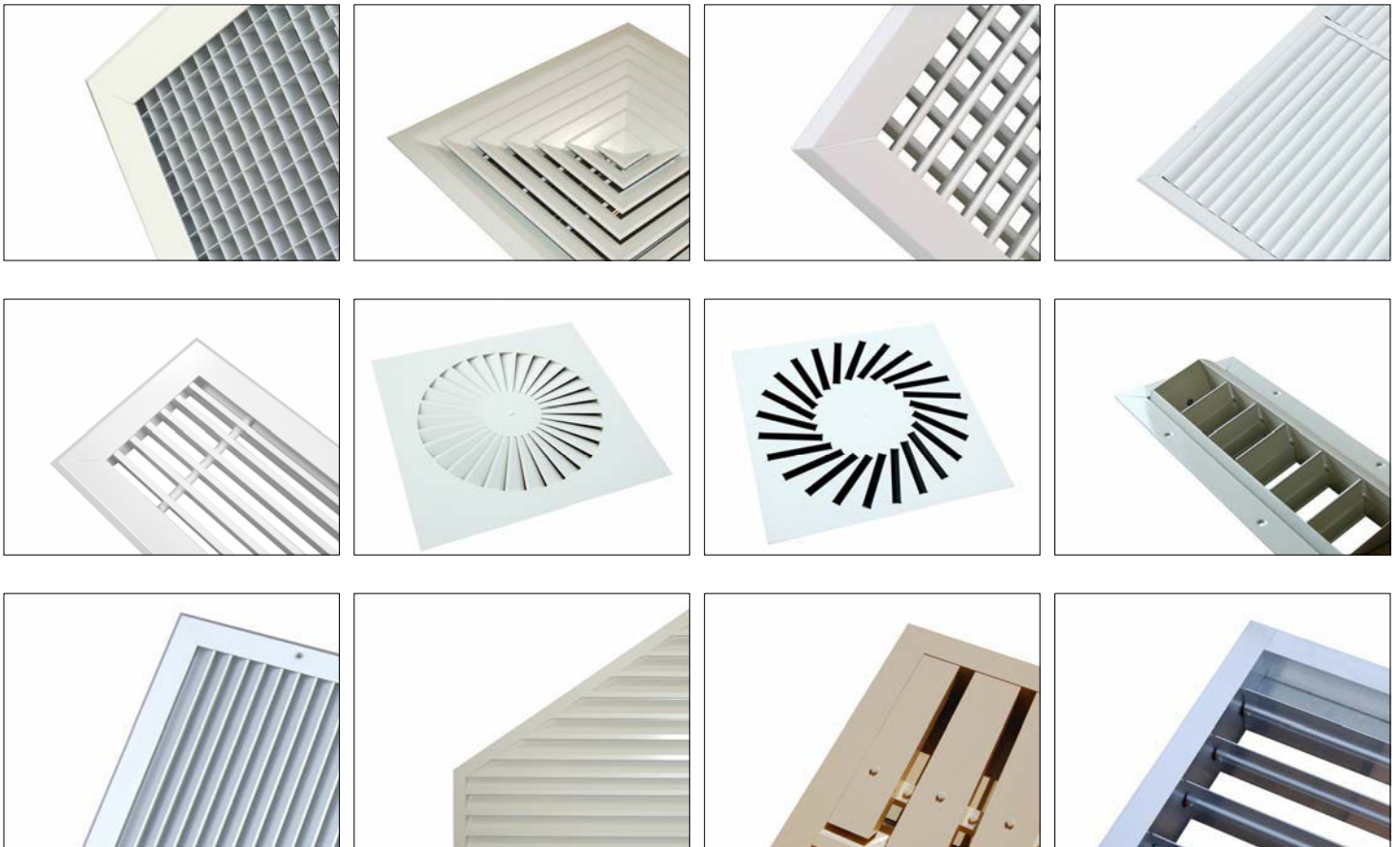

NCA: Fire and Volume Control Dampers





Assessed to ISO 9001
Cert/Ref No. 1186

HVC Supplies (Stourbridge) Ltd
Jason House
Amblecote
West Midlands
DY8 4EY
United Kingdom

Tel: +44 (0)1384 376555
Fax: +44 (0)1384 392555

sales@h-v-c.com

www.h-v-c.com

All details within this brochure are correct at time of publication. However HVC's policy is one of continual product development. The right is reserved to alter any details published in this brochure without any prior notice. Any changes will appear on www.h-v-c.com as soon as is practically possible.

All information in this brochure is designed to be used for informative purposes only. HVC will not be legally bound by anything contained within this publication, or any other information distributed.

All references to companies not part of the HVC group of companies are used with the permission of their respective owners.